

INSTALLATION GUIDE

CVR-180.2

90 minutes
Normal Install Time

Keep an eye out for these icons:

IMPORTANT!
Important installation information

Helpful Hints
Tips to assist installation

PARTS INCLUDED:

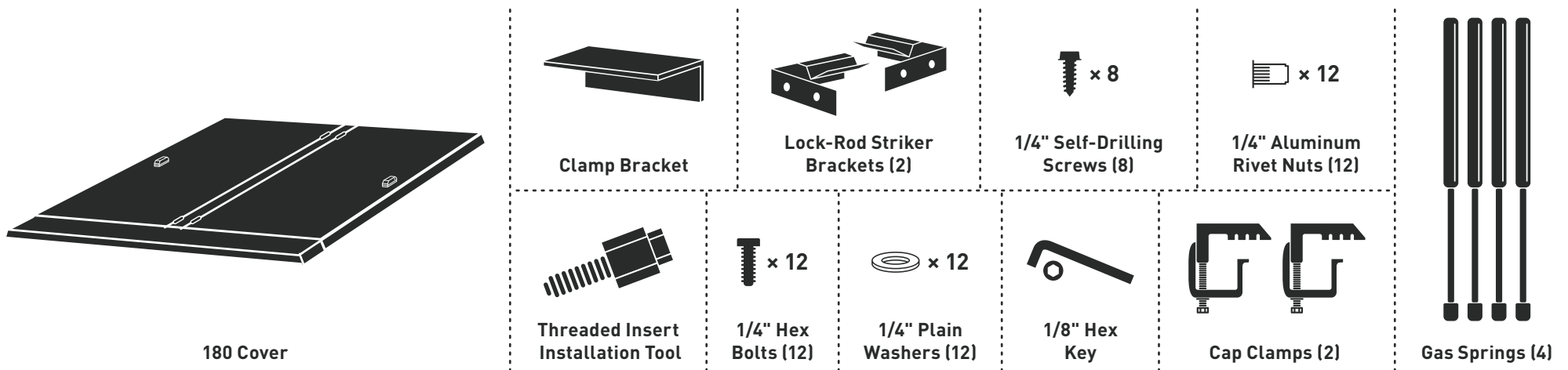

TOOLS REQUIRED:



PRE-INSTALLATION NOTE:

If your truck has bed rail caps, you should affix the included **bulkhead prep kit** prior to installing the DiamondBack 180.

PREPARE THE CARGO BED

1 Attach the **clamp bracket** to the bulkhead, centered side to side and flush with the top rail, using a drill, 3/8" nut driver bit, and four self-drilling screws.

Installing the clamp bracket is easiest if you pre-drill it using the screws.

2 Attach a **lock-rod striker bracket** to each front corner of the cargo bed, the bracket's V bend pointing rearward and the side flange located as high as possible without it breaking the plane of the top of the bed rail, using a drill, 3/8" nut driver bit, two self-drilling screws, and the two holes nearest the ends of the bracket.

It's OK for the V bend itself to break the plane of the top of the bed rail.

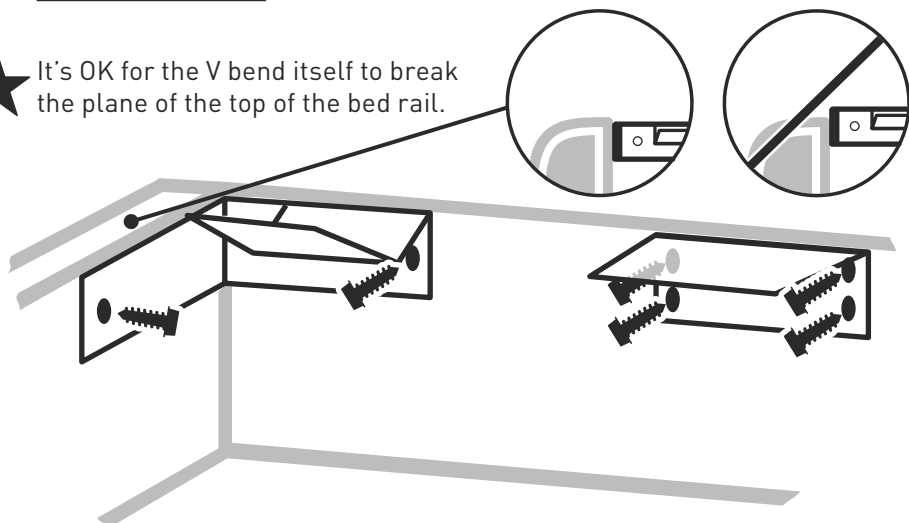

3 Detach all three brackets by removing the self-drilling screws.

4 Use the holes in the truck body left by the self-drilling screws as pilot holes to drill larger, 3/8" holes.

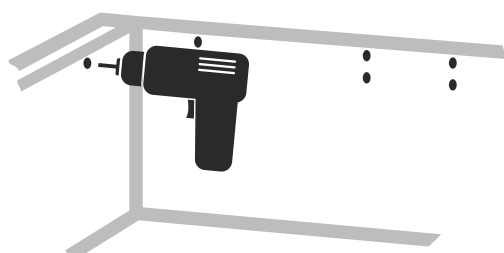

5 Hammer an aluminum rivet nut into each hole.

Do not install rivet nuts through plastic bed rail caps or plastic bedliners. (Spray-on bedliners are fine.) Use a utility knife to trim the plastic so that the rivet nuts' outer flange can sit tightly against the body of the truck itself.

6 Insert the installation-tool mandrel into a rivet nut. Hand-tighten it until its hexagonal sleeve is tight to the face of the rivet nut.

7 Use a 9/16" wrench to hold the installation-tool sleeve as you tighten the mandrel with a 7/16" socket until the rivet nut deforms and locks against the interior of the bed wall.

You'll know the rivet nut is fully compressed when you feel the mandrel become very difficult to turn.

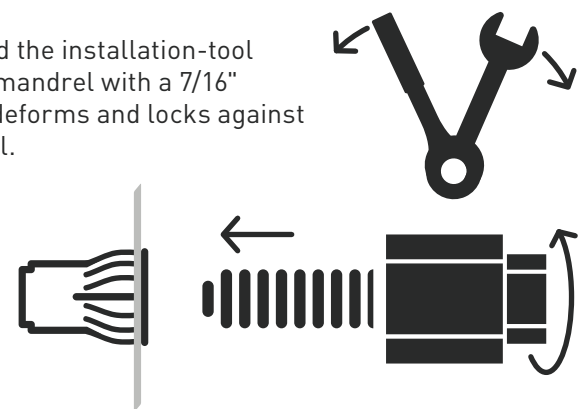

8 Remove the installation tool by unscrewing the mandrel.

9 Repeat steps 6-8 for each rivet nut.

10 Reinstall all three brackets using the hex bolts, plain washers, and a 7/16" socket.

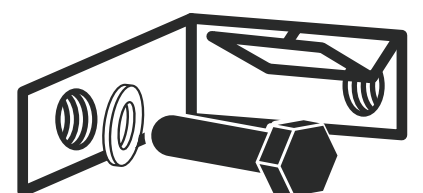

Do not overtighten the bolts or you might strip the rivet nuts.

11 If you are also installing a **Cross Bin**, do so now. Refer to page 2 of the **Cross Bin Installation Guide** for details.

ADJUST THE LOCK RODS

13 Close the tailgate. Place the cover onto the cargo bed so that the weatherstrip along the rear angle is firmly compressed against the inside edge of the tailgate.

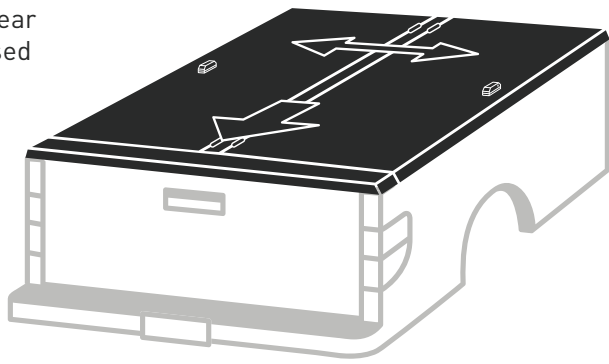

14 Center the cover side to side.

15 Attach the front of the cover to the clamp bracket using the **cap clamps**.

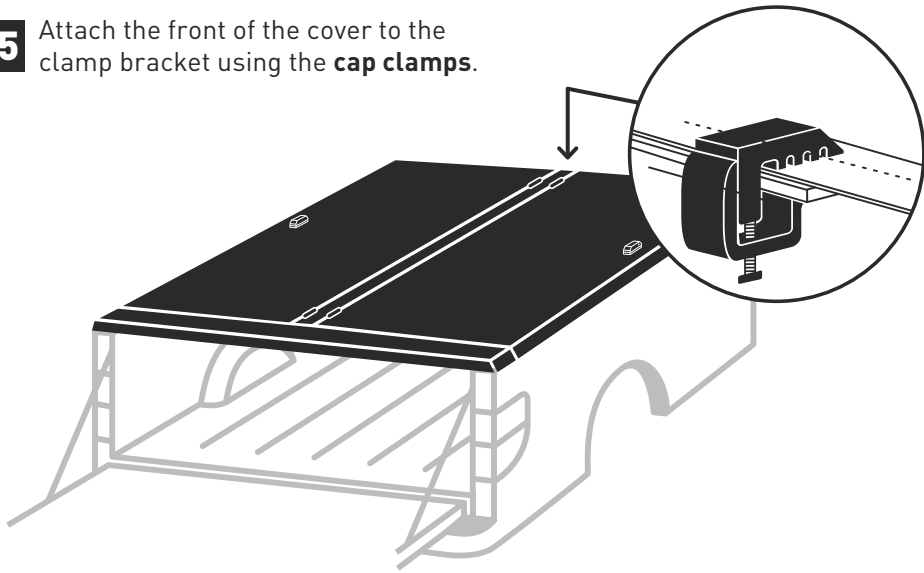

16 Verify that the cover remains centered side to side and its rear weatherstrip remains compressed against the tailgate.

17 Use a 1/8" hex key to loosen the set screws on the linkages of the driver-side lock rods.

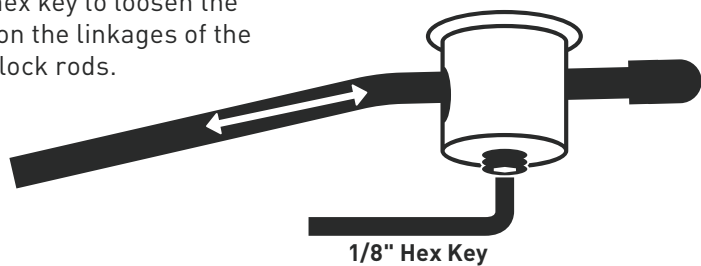

18 Adjust the length of the lock rods and retighten the set screws so that:

- A. with the lock handle in the open position, the rod tips clear the striker bracket (forward) and the T-panel gutter (rearward),
- B. with the handle in the closed position, the forward rod tip does not strike the bulkhead, and
- C. the rods point downward.

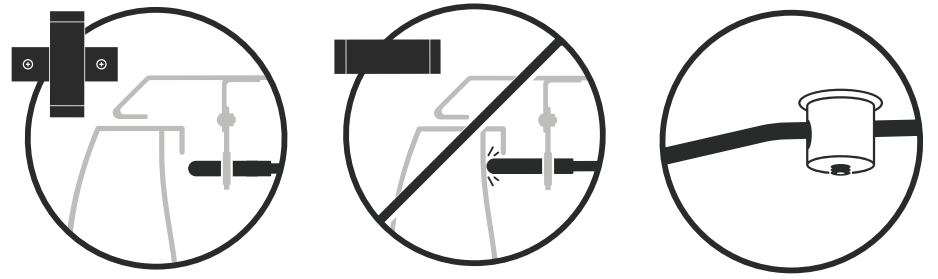

19 Position the lock rods tight against the underside of the striker brackets (forward) and T-panel gutter (rearward) so that they draw the panels down and compress the perimeter weatherstrip. Tighten the rod guide brackets with a 7/16" socket.

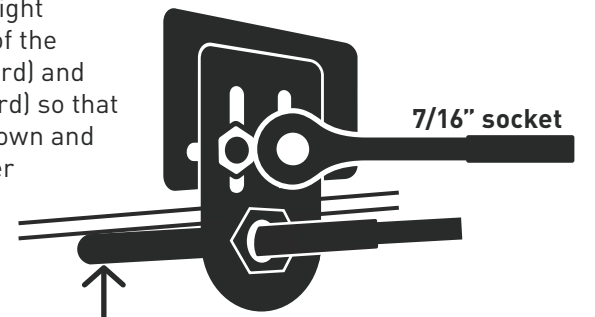

! To get the weatherstrip compression necessary for its adhesive to cure and for the cover to keep out the weather, have a second person press down on the cover while you're adjusting the lock rods.

★ If there isn't enough travel in the forward rod guide bracket to position the rod so that it presses against the striker, reshape the striker's V bend with pliers.

20 Repeat steps 17-19 for the passenger-side lock rods.

MOUNT THE COVER & ATTACH THE GAS SPRINGS

21 At the rear of the bed, mark drill locations on both bed walls using the centers of the mounting-bracket slots as a template.

★ Make these marks at about the middle of the slots so you can adjust the brackets later.

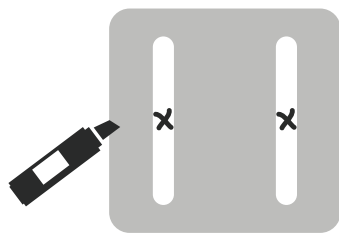

22 Unclamp and remove the cover.

23 Drill the marks with a 3/8" bit.

24 Repeat steps 5-8 to insert rivet nuts into each hole.

25 Replace and reclamp the cover. Tighten the clamps with a 9/16" socket.

! Remember to position the cover centered side to side, rear angle firmly compressed against the inside of the tailgate, and mounting-bracket slots aligning with the newly drilled holes.

26 Insert a hex bolt through a plain washer, through each bracket slot, and into each rivet nut. Tighten with a 7/16" socket.

! To get the weatherstrip compression necessary for its adhesive to cure and for the cover to keep out the weather, have a second person press down on the cover while you're inserting the bolts.

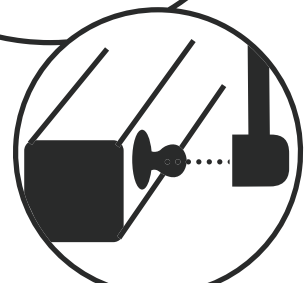
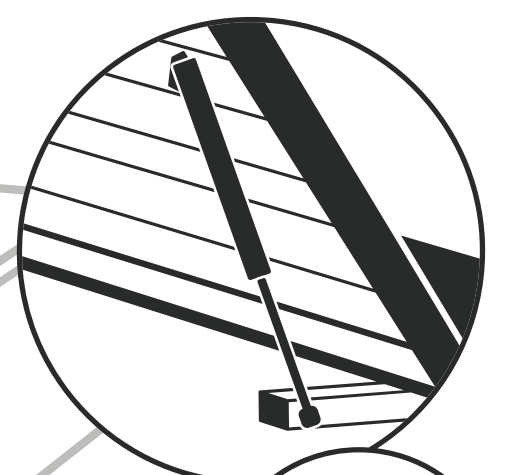
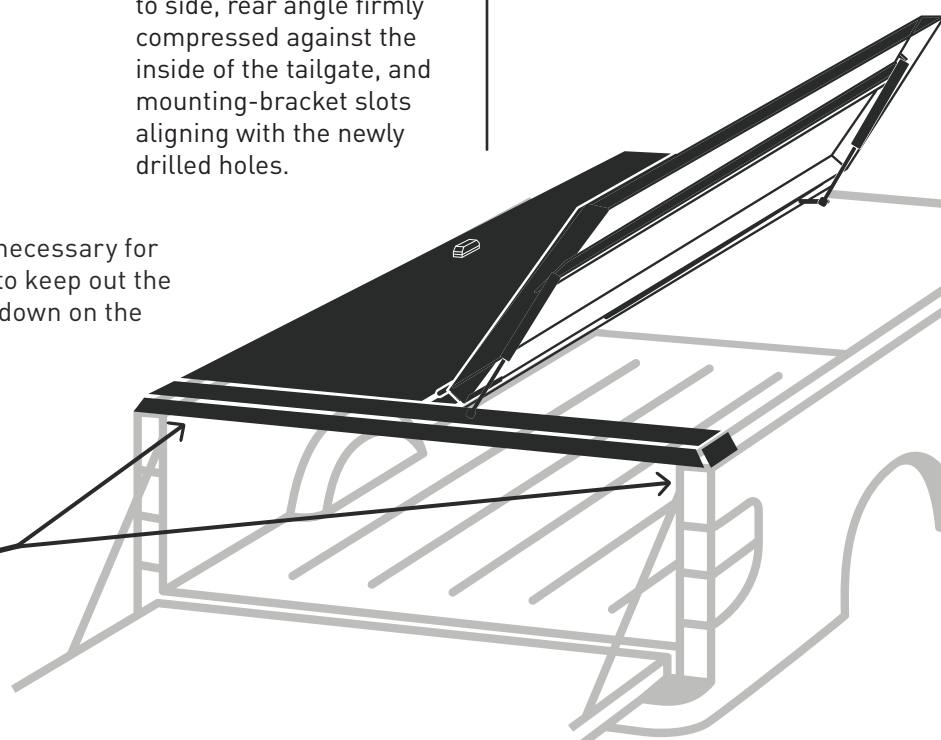
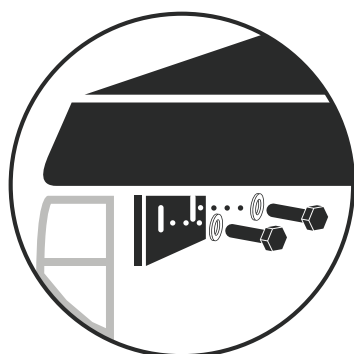

27 Double-check both panels to ensure they open, close, lock, and seal correctly. If at any point the weatherstrip does not touch the bed rails, readjust the lock rods and mounting brackets as needed.

★ Operating the access panels is easiest when you press down as you open or close them.

28 Attach the **gas springs** to the ball studs.

! To avoid premature failure of your gas springs, attach them barrel up, shaft down.

29 Leave the cover closed and locked for 24 hours to allow the weatherstrip adhesive, which is pressure-sensitive, to fully cure.