

INSTALLATION GUIDE

CVR-1

45 minutes
Normal Install Time

Keep an eye out for these icons:

IMPORTANT!
Important installation information

Helpful Hints
Tips to assist installation

PARTS INCLUDED:

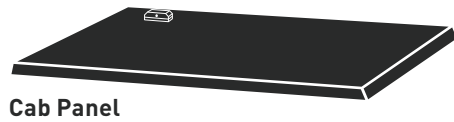

Cab Panel



Center Panel

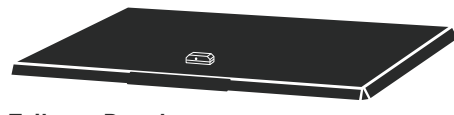

Tailgate Panel



Bed-Rail
Edge Trim (4)



1/8" Hex Key

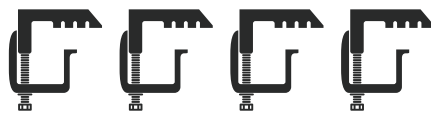

Cap Clamps (4)



Safety Catch



Gas Springs (4)

PRE-INSTALLATION NOTES:

1. If you are installing a **cab guard** or **headache rack**, you should mount it prior to mounting your DiamondBack. Refer to its installation guide for details.

2. It's possible for one person to install a DiamondBack solo, but the whole process, especially positioning the panels and adjusting the lock rods, is

TOOLS REQUIRED:



Ratchet Wrench



9/16" Socket



7/16" Socket



Utility Knife

MOUNT THE PANELS

1 Place the **center panel** across the center of bed, cheated slightly toward the tailgate.

! Make sure the arrow sticker on the underside of the center panel is pointing toward the tailgate.

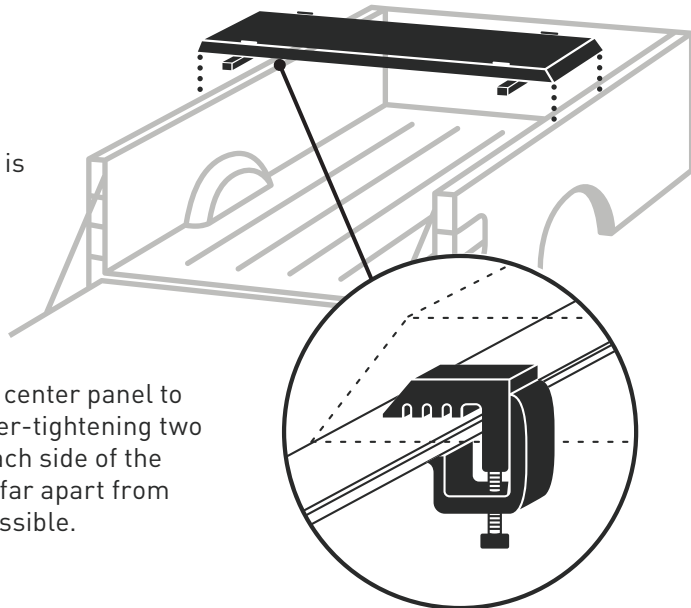

2 Loosely affix the center panel to the truck by finger-tightening two **cap clamps** at each side of the center panel, as far apart from each other as possible.

3 Slide the **tailgate panel** onto the center panel by mating their hinges. Close it slowly.

★ Mating hinges is easiest when you line up the longer, left hinge pin first.

! To avoid hinge damage, do not close the panel until the hinges are fully mated: Tilt the panel **past 90°** and push to the left until the hinge lock tabs interlock.

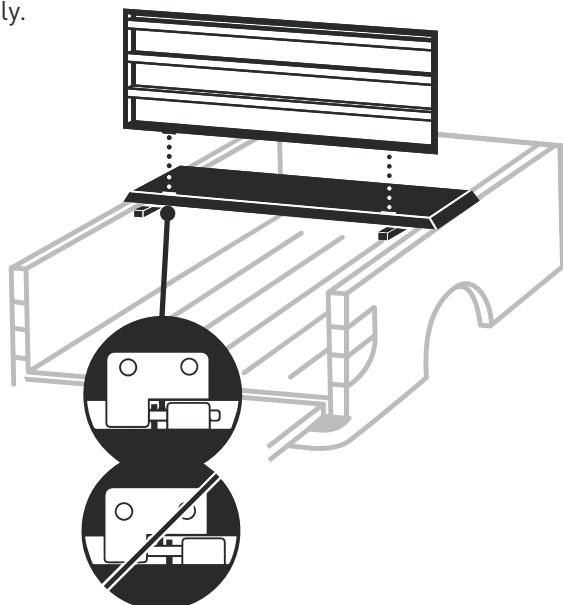

4 Repeat step 3 for the **cab panel**. Make sure it doesn't hit your cab.

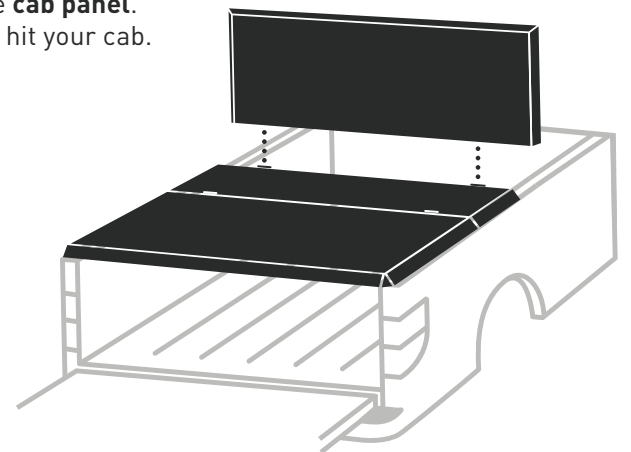

5 Position the cover front to back so that the leading edge of the closed cab panel lines up with the leading edge of the center of the bulkhead.

6 Center the cover side to side on the truck.

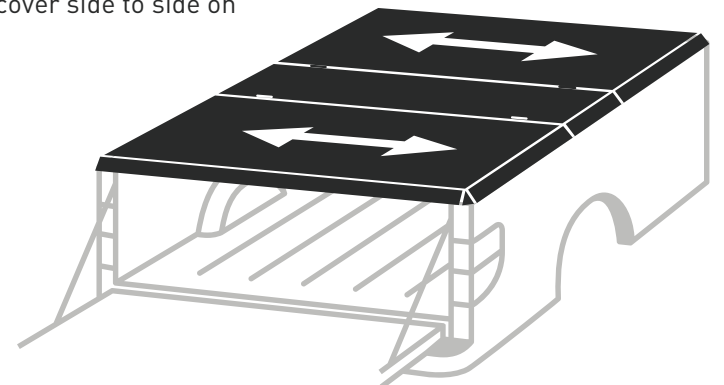

7 Tighten the cap clamps with a 9/16" socket.

! Retighten your clamps after 100 miles. Check them every time you haul on top.

ADJUST THE LOCK RODS

8 If a plastic bed liner or bed rail caps cover the vertical face of your bed rails, prepare them to receive the **bed-rail edge trim** by cutting a rectangular area the size of the trim pieces out of the plastic at each of the four places where a lock rod will pass under the bed rails.

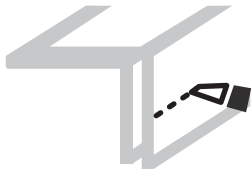

9 Peel the red adhesive backing from the bed-rail edge trim pieces. Affix one piece of trim to each of the newly cut-out, exposed metal areas of the bed rail.

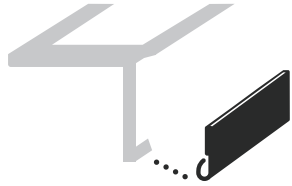

10 Loosen the set screws on the tailgate-panel lock-rod linkages.

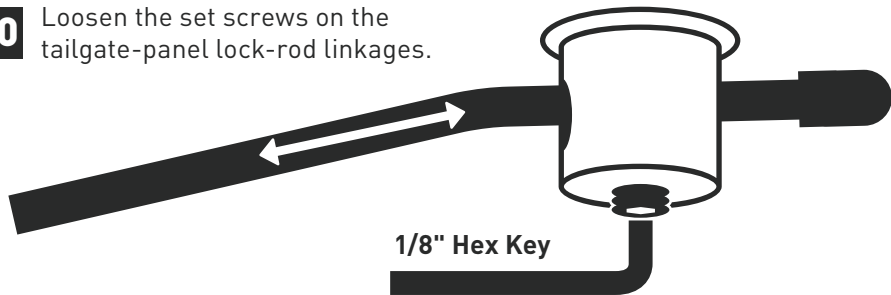

11 Adjust the length of the lock rods and retighten the set screws so that:

- A. with the lock handle in the open position, the rod tips clear the bed rails,
- B. with the handle in the closed position, the rod tips do not strike the bed walls, and
- C. the rods point downward.

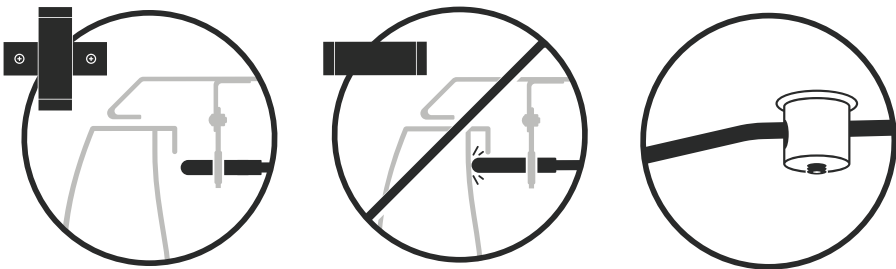

12 Position the lock rods tight against the underside of the bed rail lips so that they'll draw the panels down and compress the weatherstrip. Tighten the rod guide brackets with a 7/16" socket.

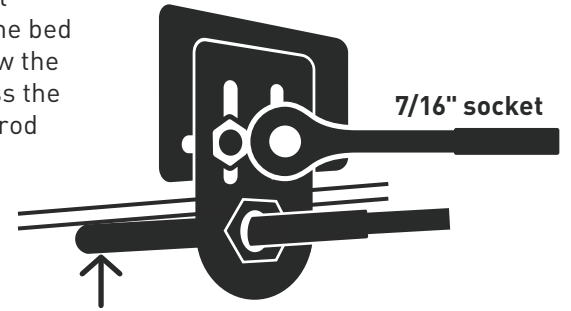

! To get the weatherstrip compression necessary for its adhesive to cure and the cover to keep out the weather, have a second person press down on the cover while you're adjusting the lock rods.



★ Using the access panels is easiest when you press down as you open or close them.



13 Repeat steps 10 through 12 for the cab panel.

★ Your panels should be very difficult to operate at first. Leave them closed as much as possible for 3-4 days to break in the weatherstrip. After that period, you should find that the panels open and close without difficulty.

ATTACH THE SAFETY CATCH & GAS SPRINGS

14 Fit the **safety catch** around the ball studs on the driver side of the cab panel.

! To ensure the safety catch works properly, attach it as shown with its slotted half up and the triangle pointing toward the cab.



15 Attach a **gas spring** to the same ball studs.

! To avoid premature failure of your gas springs, attach them barrel up, shaft down.

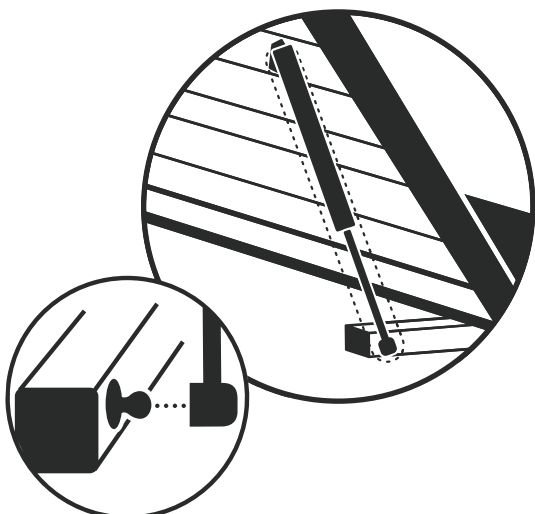

16 Attach the three remaining gas springs (barrel up, shaft down).

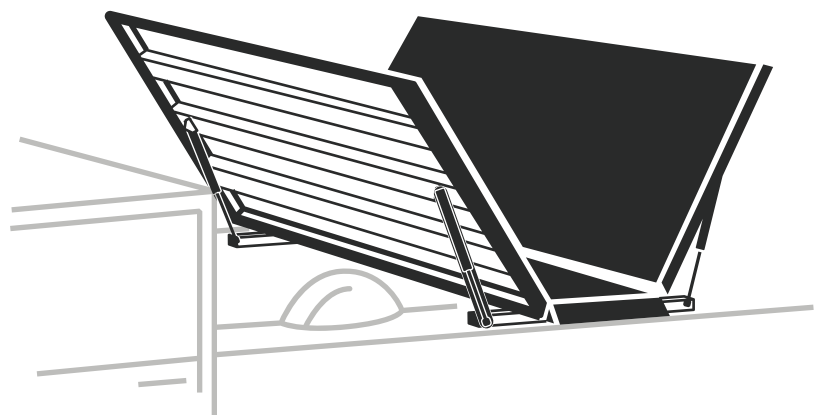

17 If your truck has bed rail caps, affix the included **bulkhead weatherstrip**. Refer to the **Bulkhead Prep Kit Installation Guide** for details.

18 Leave the cover closed and locked for 24 hours to allow the weatherstrip adhesive, which is pressure-sensitive, to fully cure.

24 hours
Adhesive Cure Time