



**DIAMONDBACK®**

# TAILGATE SEAL

Seals tailgate sides & bottom with **Taper Seal®**

Made of Long-Lasting Automotive Grade EPDM Rubber



## + Easy Install: No Drilling

Just Cut, Peel & Stick

## + Keeps Out Dust & Water



## Scan for Installation

Detailed Photo Instructions

## + Universal Truck Size

Fits most makes & models

### Trucks Excluded:

- Chevrolet Silverado w/Multi-Flex Tailgate
- GMC Sierra w/MultiPro Tailgate
- Ram w/RamBox
- Ford Maverick
- Ford Trucks with a Pro-Access Tailgate
- Sierra EV w/MultiPro Tailgate
- Silverado EV w/Multi-Flex Tailgate
- Hummer EV w/MultiPro Tailgate



Taper Seal® is a registered trademark of Extruded Solutions, Inc. Patent No.: US 10,099,544

TAILGATE SEAL

# INSTALLATION



Scan For Detailed  
Instructions & Images



**ITEMS REQUIRED:** Scissors, clean rag and soap solution. Extreme temperatures will result in poor adhesive performance. Apply only if air and surface temperature is between 55° - 105°F (13° - 40°C). Avoid touching adhesive after peeling red liner. Repositioning of seal should not be done more than 3 times and only 1 time if the temperature is above 80°F (26°C). Use enclosed adhesion promoter when attaching adhesive of seal to a non-painted surface.

## STEP 1

Clean area thoroughly with soap and water solution and wipe completely dry. Use alcohol pads to prep the tape application area and let dry.

## STEP 2: ATTACHING TO THE SIDEWALLS

Go to [TailgateSeal.com](https://TailgateSeal.com) for this step (See QR code above).

## STEP 3

Close tailgate. If you see light through the sidewalls, make adjustments by removing the seal and repositioning. If there is still light then cut pieces of seal as needed and attach to sidewalls and/or tailgate (view positioning of cut pieces on the next page, and at [TailgateSeal.com](https://TailgateSeal.com)). Do not attach adhesive to seal. Open tailgate. Apply very firm pressure (25 lbs.) to secure adhesive bond.

## STEP 4: ATTACHING TO THE TAILGATE BOTTOM GAP USING STANDARD SEAL

One minute help video available at [TailgateSeal.com](https://TailgateSeal.com) (See QR code above.)

For the following trucks go to [TailgateSeal.com](https://TailgateSeal.com) and view vehicle-specific instructions for this step: Ford Ranger, Ford F Series 2021 and newer with a hinge a retainer bracket, Hyundai Santa Cruz, Nissan Frontier, Nissan Titan, RAM with Multifunction Tailgate, Toyota Tacoma 2024 and newer.

### Positioning the Seal

1. To evaluate the best positioning for the tailgate bottom gap, cut a 1" (2.5 cm) test piece of Standard Seal, and align the top of the bulb with the truck bed floor.

2. Stand to the side of the truck and raise the tailgate until the bulb makes contact with the tailgate.

### Checking Compression

If the bulb rolls downwards just before closing the tailgate (so that you can see the tape), then the seal has rolled and compressed too much. This can cause added stress to the adhesive and possible separation. If compressing too much, invert 1" piece so that the bulb side is down. Raise the tailgate again and make sure no light is visible through the 1" piece. Adjust 1" piece higher or lower in the gap, as needed, to block the light.

### Installing the Seal

After determining if the bulb should be up or down and how high or low, remove 1" piece and pick up one end of the continuous seal. Peel back a 1-2ft (30 to 61cm) section of liner. Start at either end and press it in place so that it sits flush with the seal on the sidewall. Attach in 1-2" (2.5-5cm) sections and apply light pressure to the adhesive. Reposition as needed but no more than 3 times and only 1 time if the temperature is above 80°F (27°C). Stop when 6" (15 cm) from the opposite end. Keeping adhesive off surface, cut seal where it will sit flush with the seal on the sidewall. Continue attaching. After seal is in place, apply very firm pressure (25lbs.), to secure the adhesive bond.

### STEP 5

After seal is in place, apply very firm pressure (25 lbs.) to secure the entire adhesive bond. Leave tailgate open for 60 minutes. If air temperature will fall below 50°F (10°C) within the next 24 hours or, if applying to a surface other than paint, such as plastic or a spray-on bed liner, then leave tailgate open for 24 hours.

### 3 MOST COMMON CUT PIECE POSITIONS FOR TOP OF SIDEWALLS

Substitute Standard with Large Seal as needed.

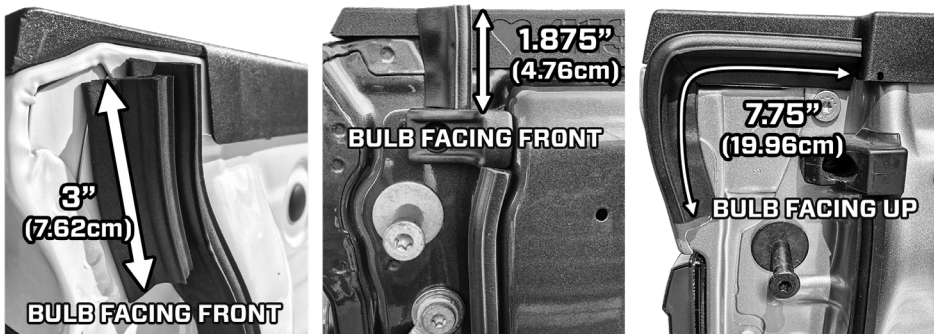

### 3 MOST COMMON CUT PIECE POSITIONS FOR INSIDE OF TAILGATE

Substitute Standard with Large Seal as needed.

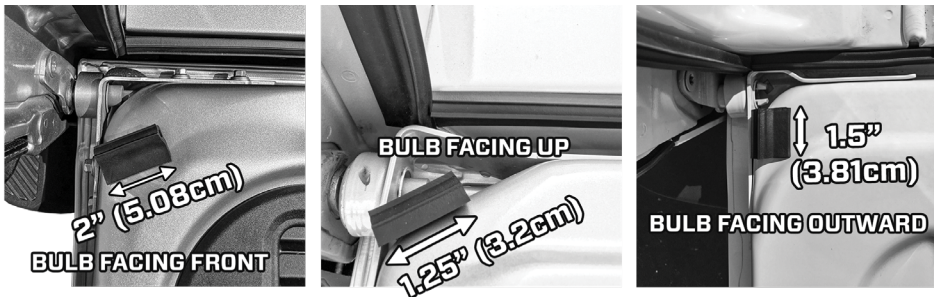

### 3 MOST COMMON CUT PIECE POSITIONS FOR TOP OF TAILGATE

Substitute Standard with Large Seal as needed.

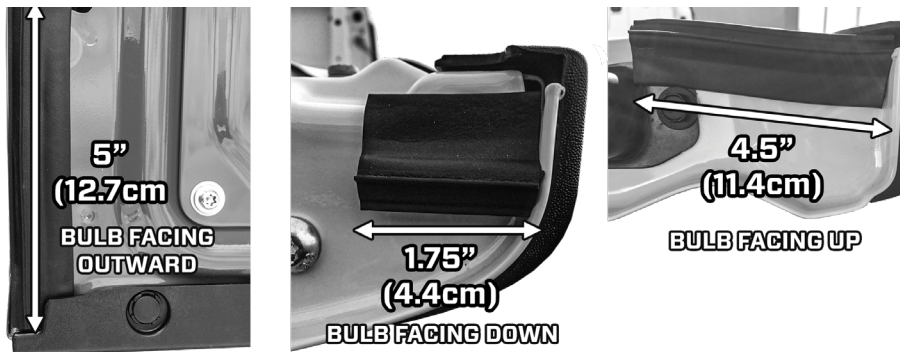

Taper Seal® is a registered trademark of Extruded Solutions, Inc. Patent No. US 10,099,544

