



**DIAMONDBACK**

DiamondBackCovers.com / 800 935 4002

# SIDE BOXES

## INSTALLATION GUIDE

AX-11

**20 minutes**  
Normal install time

Keep an eye out for these icons:

**! IMPORTANT!**  
Important installation information

**★ Helpful Hints**  
Tips to assist installation

### PARTS INCLUDED:

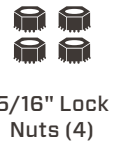
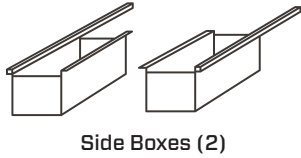

### TOOLS REQUIRED:



### PRE-INSTALLATION NOTES:

You must install your DiamondBack cover prior to installing the Side Boxes. Refer to the **Diamond-Back HD/SE or 270 Installation Guide** for details.

Use of Side Boxes with the DiamondBack ToolBar may require trimming of the ToolBar.

## MOUNT THE FIRST BOX

**1** Remove both access panels of the cover by detaching their gas springs, tilting the panels to 90 degrees, and sliding them off their hinges.

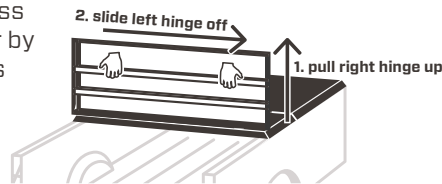

**2** Set one **Side Box** under the cover so that:  
a. its square tube arm is underneath the center panel,  
b. its support flange is on the truck bed rail, and  
c. its rear edge is tight against the center-panel gutter.

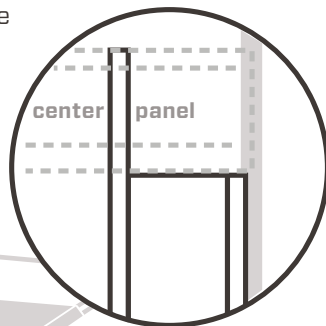

**3** Clamp the square tube arm in place.

**4** Drill down through the center-panel gutter closest to the side box and through the square tube arm using a 5/16" bit.

**★** Locate this hole as far toward the side box as possible.

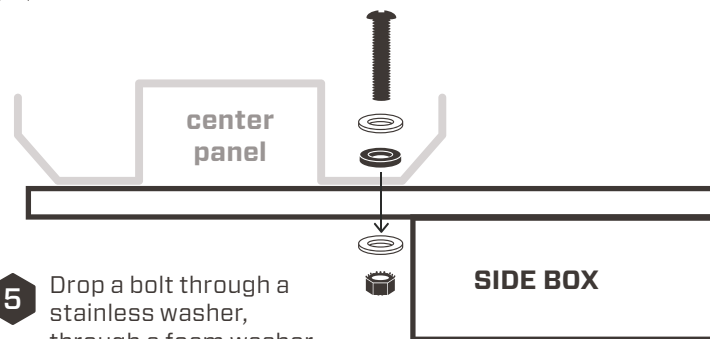

**5** Drop a bolt through a stainless washer, through a foam washer, and into the new hole.

**6** Put a stainless washer and lock nut onto the bolt end. Tighten the lock nut with a 1/2" socket and 3/16" hex key.

**!** Do not crush the square tube arm.

# MOUNT THE SECOND BOX

- 7** If you plan to mount the second box on the opposite side of the truck, finish installing the first box by repeating steps 4-6 at the far end of its square tube arm, through the other center-panel gutter.

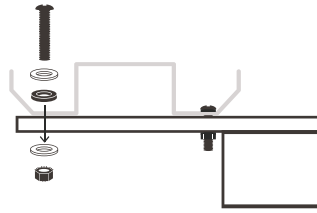

- ★ If you plan to mount the second box inline with the first, skip to step 9.

- 8** To mount the second box on the opposite side of the truck, repeat steps 2-7, then skip to step 13.

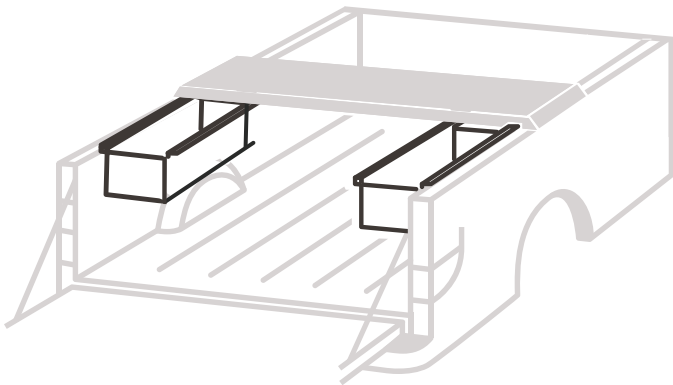

- 9** To mount the second box inline with the first, repeat steps 2-6.

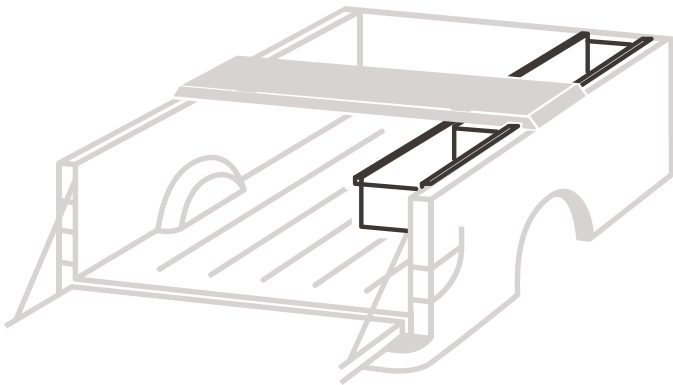

- ★ The boxes' square tube arms should pass by and align with each other under the center panel. (One box is slightly narrower than the other.)

- 10** Drill two holes that travel through both arms using a 5/16" bit.

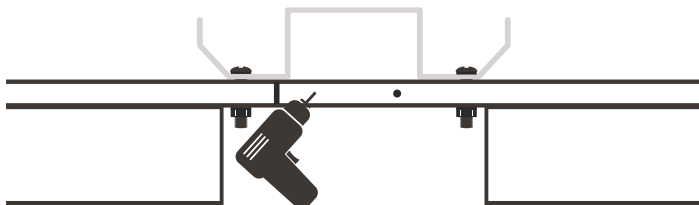

- 11** Insert a bolt through each new hole.

- ! Point the bolt ends toward the bed rails.

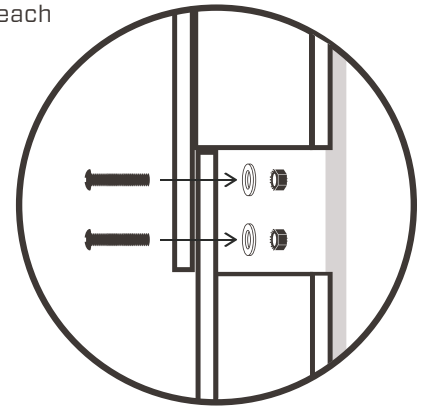

- 12** Put a plain washer and lock nut onto each bolt. Tighten each lock nut with a 1/2" socket and 3/16" hex key.

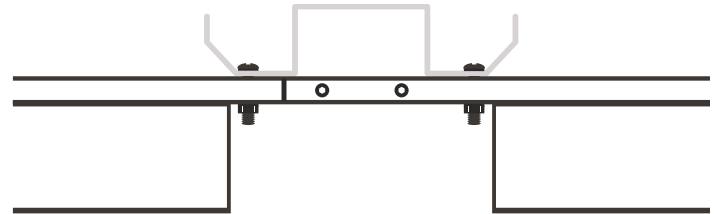

- 13** Reattach the access panels of the cover by tilting them to 90 degrees, fully mating their hinges, and reattaching their gas springs.

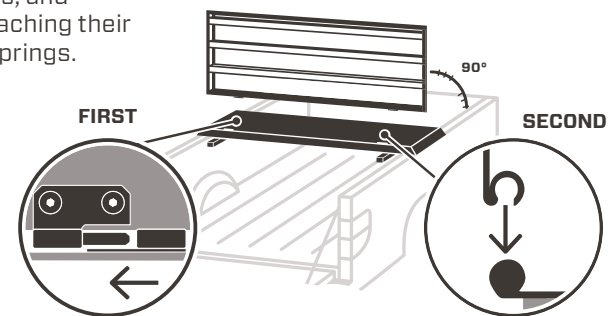

- ! To avoid hinge damage, make sure to fully mate the hinges before bringing the cab panel back into its closed position.



- ! If you have installed a Side Box under the driver side of the cab panel, remember to keep the cargo in the box clear of safety catch to avoid interference.